

Description

The DCSMF33C is a 3.3V TVS array, utilizing leading monolithic silicon technology to provide fast response time and low ESD clamping voltage, making this device an ideal solution for protecting voltage sensitive high-speed data lines. The DCSMF33C complies with the IEC 61000-4-2 (ESD) standard with $\pm 30\text{kV}$ air and $\pm 30\text{kV}$ contact discharge. It is assembled into a 6-pin lead-free SOT-363 package. The low clamping voltage array make it ideal for use in portable electronics such as cell phones, PDAs, and digital cameras.

Mechanical Characteristics

- ◆ Package: SOT-363
- ◆ Lead Finish: Matte Tin
- ◆ Case Material: "Green" Molding Compound
- ◆ Moisture Sensitivity: Level 3 per J-STD-020
- ◆ Terminal Connections: See Diagram Below
- ◆ Marking Information: See Below

Dimensions and Pin Configuration

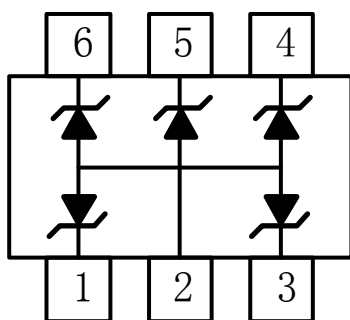

Circuit and Pin Schematic

Features

- ◆ Low leakage current
- ◆ Operating voltage: 3.3V
- ◆ Low clamping voltage
- ◆ JEDEC SOT-363 package
- ◆ Complies with following standards:
 - IEC 61000-4-2 (ESD) immunity test
 - Air discharge: $\pm 30\text{kV}$
 - Contact discharge: $\pm 30\text{kV}$
 - IEC61000-4-5 (Lightning) : 8A(8/20 μs)
- ◆ ROHS Compliant

Applications

- ◆ Peripherals
- ◆ Industrial Equipment
- ◆ Notebook Computers
- ◆ Portable Instrumentation
- ◆ Microprocessor Based Equipment
- ◆ Cell Phone Handsets and Accessories
- ◆ Personal Digital Assistants (PDAs) and Pagers

Marking Information

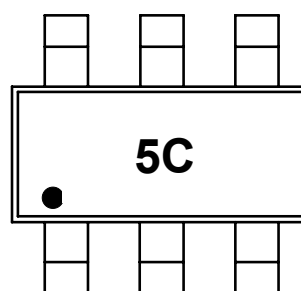

5C = Device Marking Code

Ordering Information

Part Number	Marking	Packaging	Reel Size
DCSMF33C	5C	3000/Tape & Reel	7 inch

Absolute Maximum Ratings ($T_A=25^{\circ}\text{C}$ unless otherwise specified)

Parameter	Symbol	Value	Unit
Peak Pulse Power (8/20 μs)	Ppk	100	W
Peak Pulse Current (8/20 μs)	I _{PP}	8	A
ESD per IEC 61000-4-2 (Air)	V _{ESD}	± 30	kV
ESD per IEC 61000-4-2 (Contact)		± 30	
Operating Temperature Range	T _J	-55 to +125	$^{\circ}\text{C}$
Storage Temperature Range	T _{stg}	-55 to +150	$^{\circ}\text{C}$

Electrical Characteristics ($T_A=25^{\circ}\text{C}$ unless otherwise specified)

Parameter	Symbol	Min	Typ	Max	Unit	Test Condition
Reverse Working Voltage	V _{RWM}			3.3	V	
Reverse Breakdown Voltage	V _{BR}	4			V	I _T = 1mA
Reverse Leakage Current	I _R			0.2	μA	V _{RWM} = 3.3V, any I/O pin to ground
Clamping Voltage	V _C			8	V	I _{PP} = 1A (8 x 20 μs pulse), any I/O pin to ground
Clamping Voltage	V _C			12	V	I _{PP} = 8A (8 x 20 μs pulse), any I/O pin to ground
Junction Capacitance	C _J		60		pF	V _R = 0V, f = 1MHz, any I/O pin to ground

Note 1: I/O pins are Pin 1, 3, 4, 5, 6

Typical Performance Characteristics (TA=25°C unless otherwise Specified)

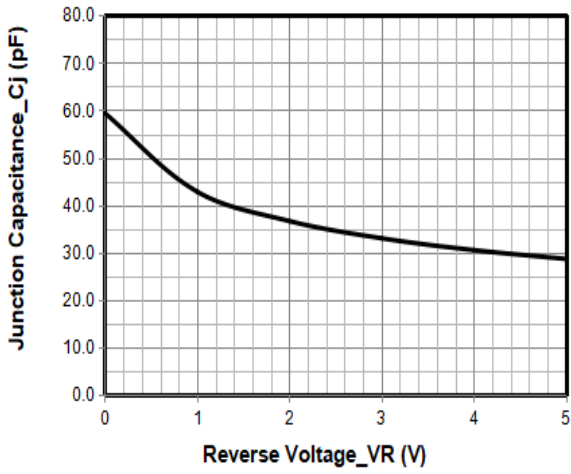

Junction Capacitance vs. Reverse Voltage

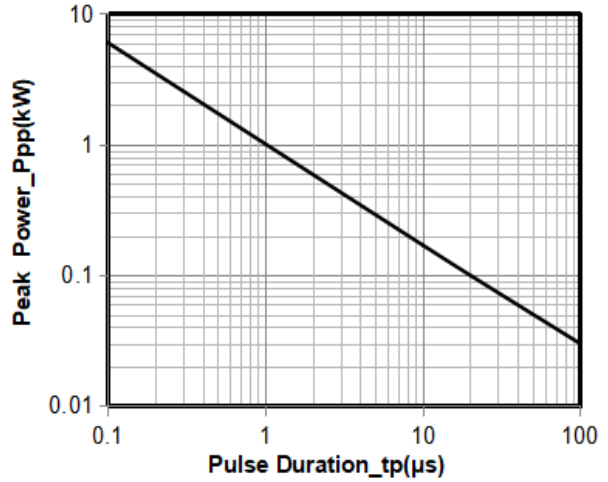

Peak Pulse Power vs. Pulse Time

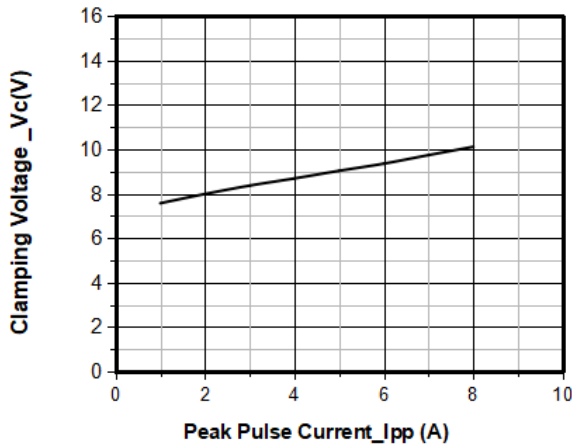

Clamping Voltage vs. Peak Pulse Current

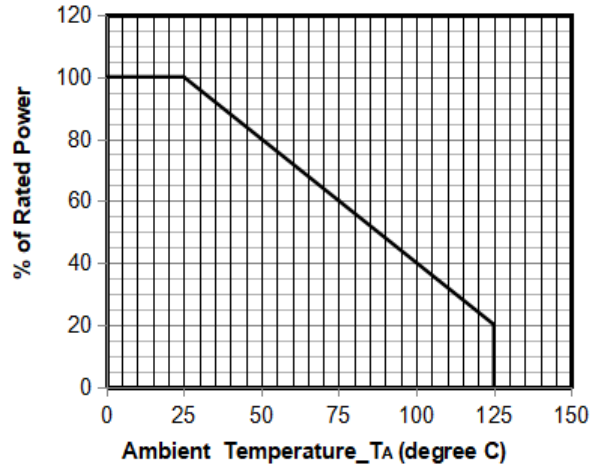

Power Derating Curve

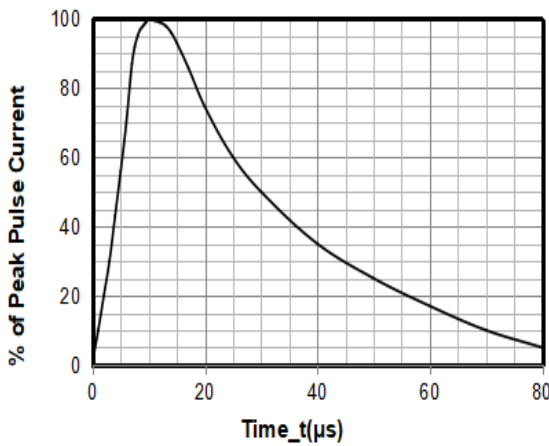

8 X 20μs Pulse Waveform

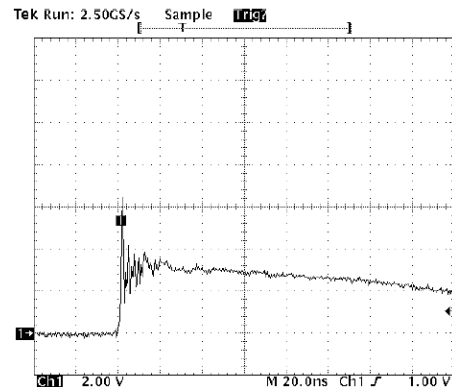

Note: Data is taken with a 10x attenuator
ESD Clamping Voltage
8 kV Contact per IEC61000-4-2

SOT-363 Package Outline Drawing

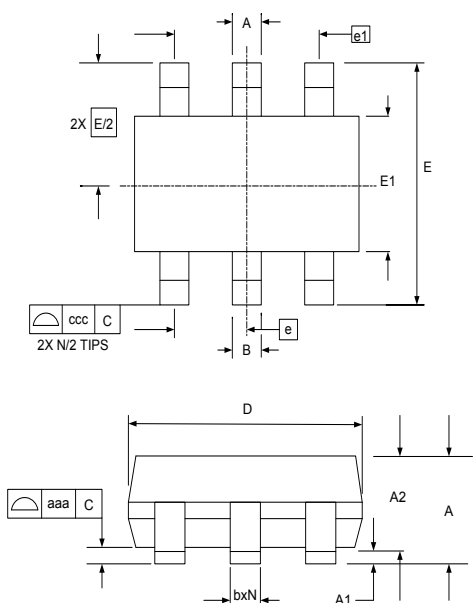

SYM	DIMENSIONS					
	MILLIMETERS			INCHES		
	MIN	NOM	MAX	MIN	NOM	MAX
A			1.10			0.043
A1	0.00		0.10	0.000		0.004
A2	0.70	0.90	1.00	0.028	0.035	0.039
b	0.15		0.30	0.006		0.012
c	0.08		0.22	0.003		0.009
D	1.80	2.00	2.20	0.071	0.079	0.087
E1	1.15	1.25	1.35	0.045	0.049	0.053
E	2.10 BSC			0.083 BSC		
e	0.65 BSC			0.026 BSC		
e1	1.30 BSC			0.051 BSC		
N	6			6		
aaa	0.10			0.004		
ccc	0.30			0.012		

Suggested Land Pattern

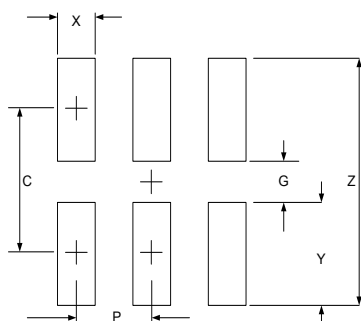

SYM	DIMENSIONS	
	MILLIMETERS	INCHES
C	1.85	0.073
G	1.00	0.039
P	0.65	0.026
X	0.40	0.016
Y	0.85	0.033
Z	2.70	0.106

Contact Information

Changzhou D-first Electronics CO.,Ltd.

www.first-electronic.com

Email: xhf@first-electronic.cn

Phone: +86 (0519) -8817 1671